



SERVICE BULLETIN

Classification: BT02-012	Reference: NTB02-036	Date March 27, 2002
-----------------------------	-------------------------	------------------------

SEATBACK BOARD REMOVAL PROCEDURE

APPLIED VEHICLE(S): 2000 – 2002 Maxima (A33)
2002 Altima (L31)

SERVICE INFORMATION

Use the procedure in this bulletin to properly remove the “seatback board” on a left or right front seat when a repair requires access to the inner seatback on an applied model.

Damage to the “seatback board”, “brackets”, or “attaching clips” may occur if the service procedure in this bulletin is not used.

Following the steps in this procedure properly will help prevent damage to the seatback board caused by incorrect removal procedures.

SERVICE PROCEDURE

1. Slide and tilt the seat back completely forward to allow for working room.

NOTE:

- The seatback board is held in place by two brackets at the top and four attaching clips (two in the middle and two at the bottom) as shown in figure 1.
- The brackets shown at the top of the seatback board do not pull loose. **First**, the middle and bottom clips must be removed, then the brackets at the top will slide out by pulling down on the seatback board.

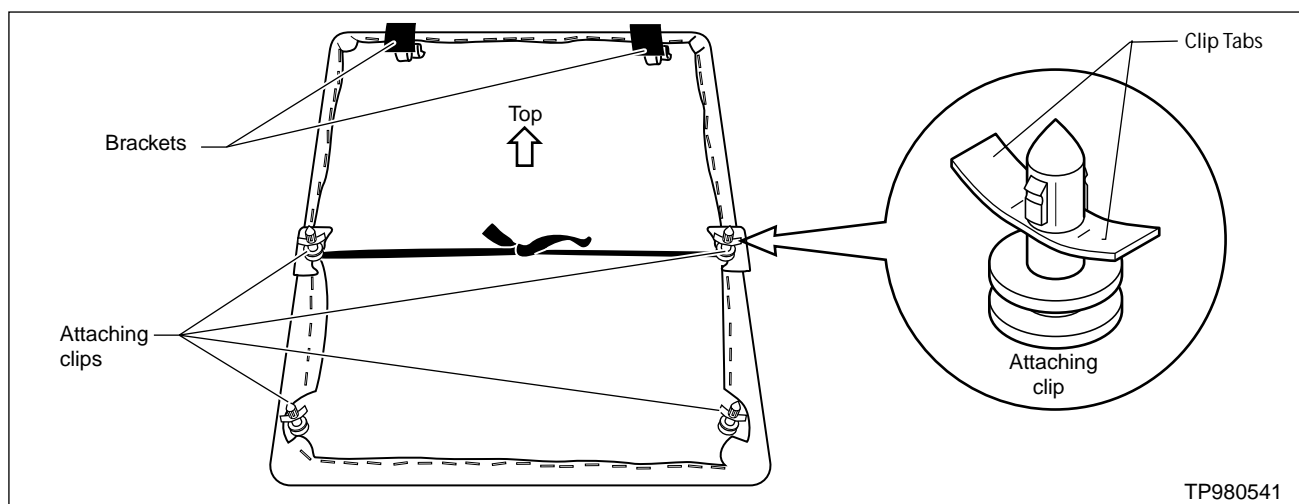

Figure 1 (Seatback board removed)

- Place your hand between the seatback and the seatback board. **Gently** pull out on the seatback board (left or right side) just enough to see the attaching clips (see figure 2).

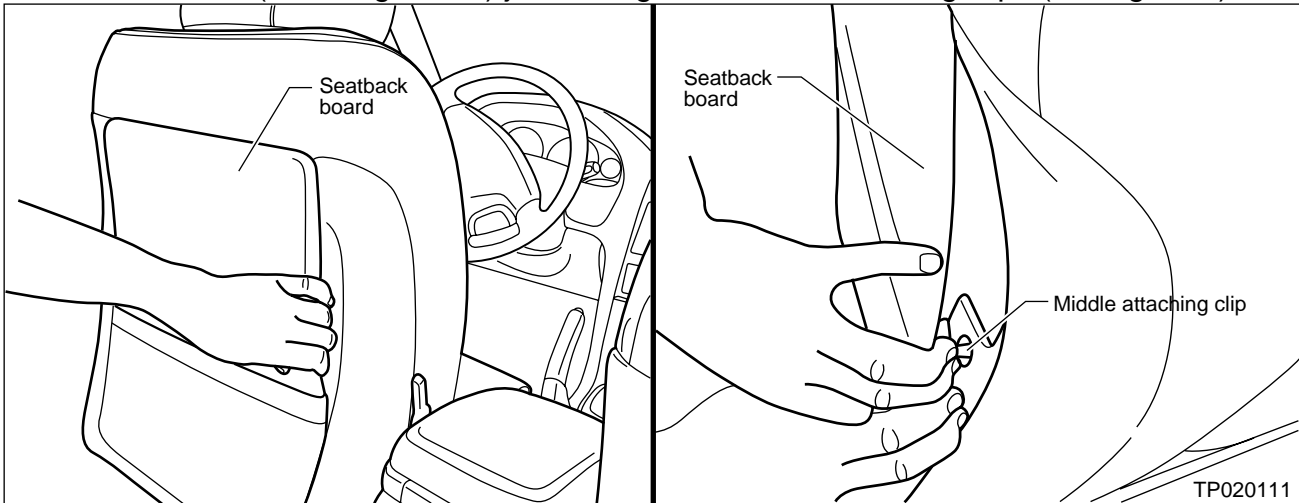

Figure 2

- Use a Trim Pad Removal tool (Snap-on A177A or equivalent) to remove the middle and bottom attaching clips (see figure 3).

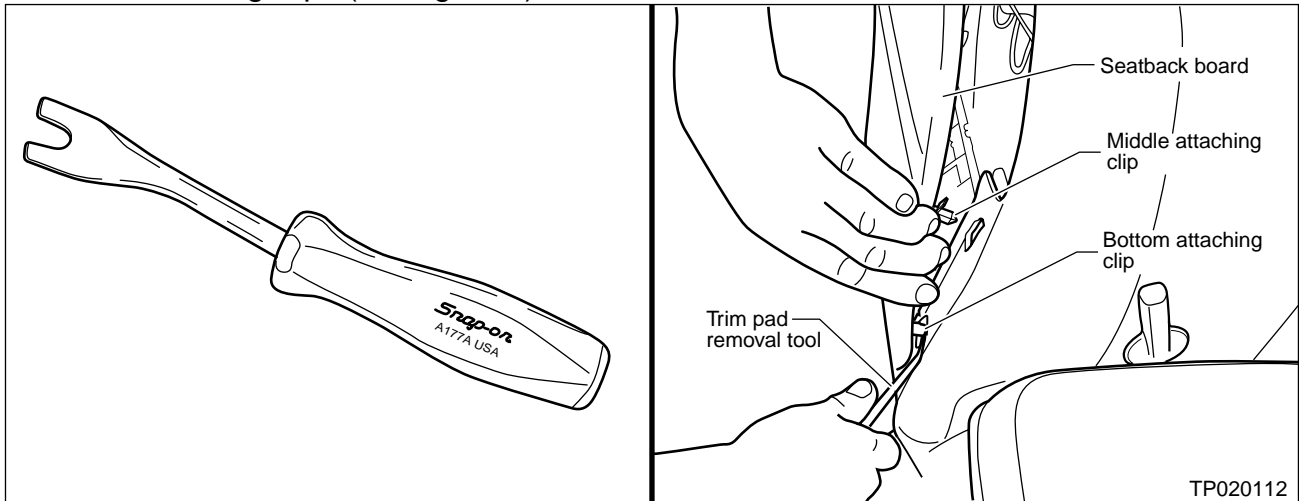

Figure 3

The Trim Pad Removal tool must be inserted **under the attaching clip Tabs** (see figures 4).

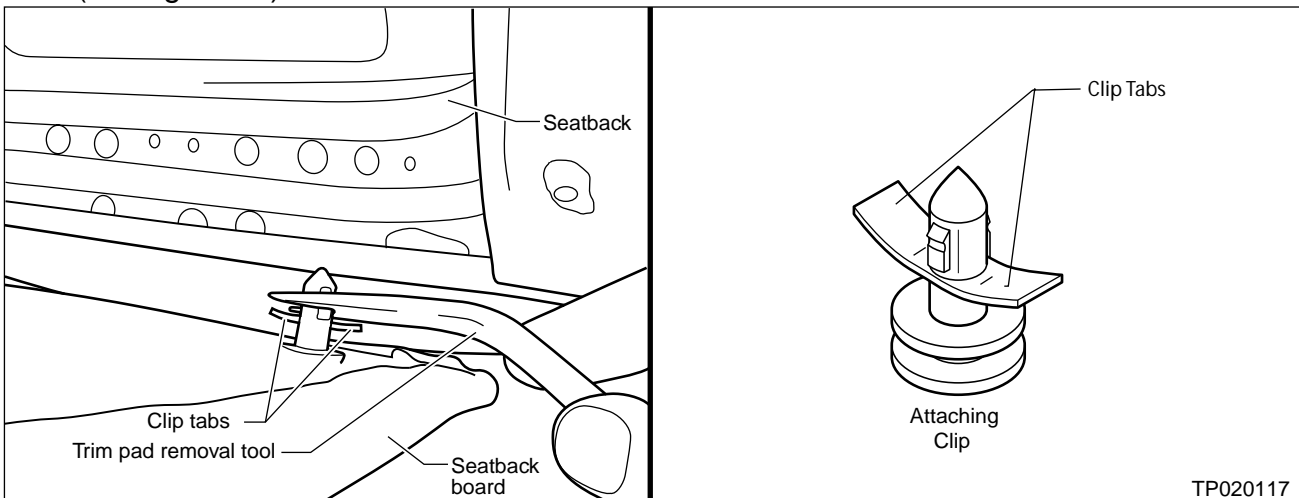

Figure 4

If the tool is not inserted under the attaching clip Tabs damage to the seatback board may occur (see figure 5).

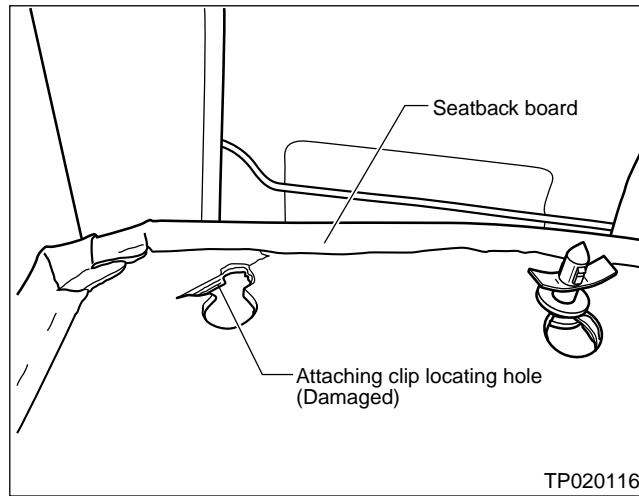

Figure 5

4. Twist the Trim Pad Removal tool from side to side, **“walking” the attaching clip out “a little at a time”** until it is released.
5. Repeat steps 3 and 4 for all attaching clips (Qty 2 per side/total Qty 4), making sure not to damage the seatback board or the brackets.
6. After all attaching clips are released, the brackets at the top of the seatback board will slide out by pulling down on the seatback board (see figure 6).

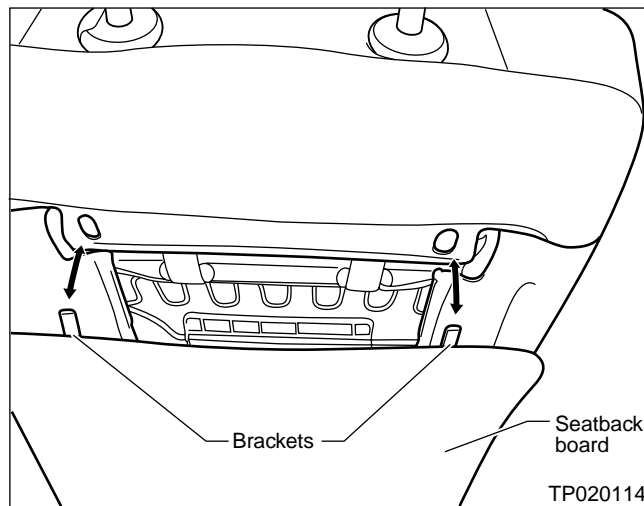

Figure 6

For Installation:

7. Confirm all attaching clips are correctly aligned in seatback board (see figure 1).
8. First, align the brackets at the top of the seatback board with the holes in the seatback, slide the brackets into place by pushing the seatback board up (see figure 6).
9. Pop the attaching clips into place by gently pushing in on the seatback board at each attaching clip location, insuring that the attaching clips positively lock in place.
10. Check for proper installation by gently lifting/pulling on the seatback board. Confirm that all sides are tight and flush against the seatback.

NOTE: If the seatback board is damaged (see figure 5) the following may occur:

- Seatback board may not install correctly.
- The top or sides may be loose and/or protrude away from the seatback.
- If a damaged seatback board is installed, it may come loose during vehicle use.
- Customers may have to return for additional repairs.

